

WORSHIP & HALL Series

2Way passive, ultra compact, processor controlled loudspeaker system

Audio-Performance Worship & Hall SB2

The SB2 loudspeaker is a compact device designed to perform in a wide range of public address and sound reinforcement applications. It is a 2Way passive system, consisting of one proprietary 5-inch low frequency driver and one 1-inch high frequency dome tweeter loaded with a horn, housed in a vented enclosure.

The enclosure is black, white or any RAL (on option) epoxy painted and fitted with M8 screws on top and bottom and on each side. On the back, two Speakon connectors allow easy parallel connection. The front of the speaker is protected by a perforated metal grill and inside covered with charcoal grey foam.

The SB2 loudspeaker is designed to operate with the P212 SB2-E processor, unit which contains speaker sense, drivers protection, amplitude and phase response alignment circuitry, optimized for this loudspeaker.

The P212 SB2-E processor allows the loudspeaker to be operated at full capacity with maximum fidelity and reliability.

The P212 SB2-E is a two channels processor with an optional SUB board controller for low frequency reproduction with the AP range of subwoofer's.

IDEAL FOR

Theatres
Radios, TV

Clubs, Discos
Restaurants, Bars
Conference rooms

Sound Effects

Multi Media



Special Features

high efficiency

low distortion

electronically controlled

WORSHIP & HALL Series

Hall SB2 Specifications

Acoustical

frequency response (1)
70-20'000 Hz \pm 3dB

power handling
70W (AES) (4)

max. peak SPL (2)
114dB

crossover frequency (3)
3500Hz, 24dB per octave

Transducers

LO section
1 x 5", long excursion, low distortion cone driver

system nominal impedance
8 Ohms

HI section
1" dome tweeter,
fabric diaphragm loaded with horn

connectors
IN / OUT (loop): Neutrik SPEKON NL4MP
1+, 1-
2+, 2-, linked

Mechanical data

cabinet
5 liters, vented

finish
rounded edges and corners, the outer surface is hard-wearing painted (black, white or any RAL colour).
front metal grill.

mounting system
four fasteners M8 screws (top/bottom & sides) AP-U-SB2 (vertical) or C-SB2 (horizontal) brackets.

cabinet size (W x H x D)
180 x 290 x 225mm

weight
4 kg

Options

AP-C-SB2 or U-SB2 brackets
RAL colour

WORSHIP & HALL Series

Ultra compact system

P212, 2 Channels, 2 Way analogue Processor

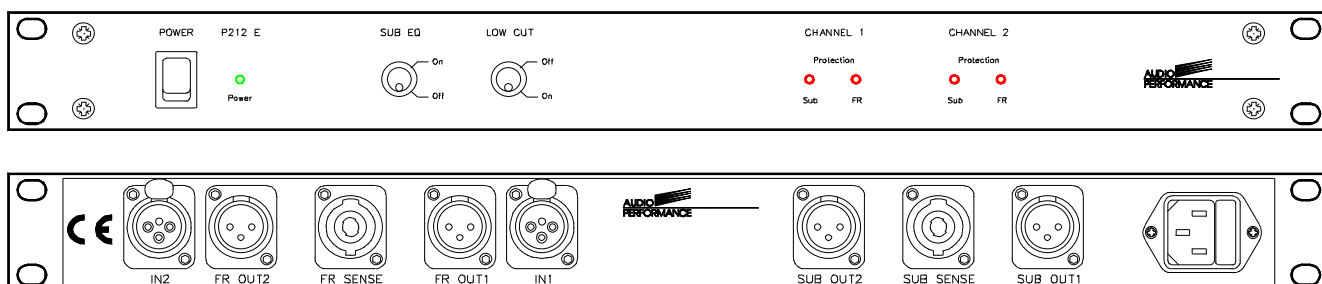

The Audio Performance P212 SB2 is an advanced electronic Processor which will optimise the performance of the Audio Performance SB2 passive loudspeaker system.

The P212 SB2 contains an electronic processor with frequency response phase alignment circuitry, analogue delays and Audio Performance's exclusive Sense Inputs driver protection circuitry, incorporating true RMS signal limiting.

Sense Inputs driver protection circuitry protects the loudspeaker components from damage due to overheating under high power conditions

This circuit continuously monitors the power applied to the drivers and limits the controller outputs when the safe operating limits of the drivers are exceeded. Until the onset of overload, the Sense Inputs driver protection has no effect on the signal.

Operating at line level, the P212 SB2 is the final component in the signal chain before the amplifier.

A high pass-filter can be switched to increase the intelligibility for speech applications.

An optional plug-in subwoofer module allows the user to increase the low frequency response of the system, down to 45 Hz

Specification & electrical data

Front panel

POWER: Main switch with Power On indicator: green Led

SUB EQ switch:

Off: SB2 outputs full range, On: SB2

LOW CUT switch:

Off, On

LIMIT: Red's LED for SB2 and Sub

Rear panel

MAIN: Main input with fuse holder and internal voltage switch for 115 - 230 V operation

INPUTS: XLR 3pin, 20KW electronically balanced, maximum level +20dBu. Pin 1: GND, Pin 2: +, Pin 3 -

OUTPUTS: XLR 3pin, 50W electronically balanced, maximum level +20dBu. Pin 1: GND, Pin 2: +, Pin 3 -

SENSE INPUTS: SPEAKON NL4MP 4pin 100KW electronically balanced.

Mechanical data

dimensions: 19", 1U (483 x 45 x 310mm) W x H x D
weight: 2.5 kg

shipping dimensions: 530 x 65 x 430mm W x H x D
weight: 3.5kg

WORSHIP & HALL Series

Ultra compact system

Hall SB2 Specifications

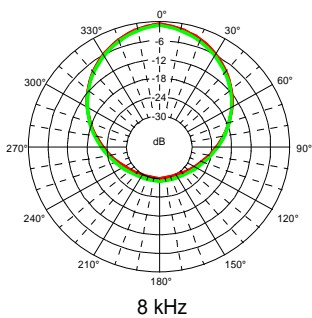
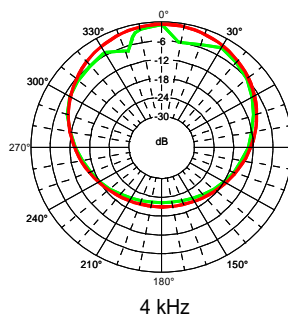
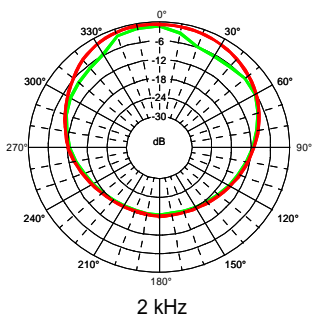
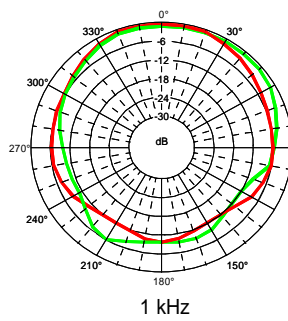
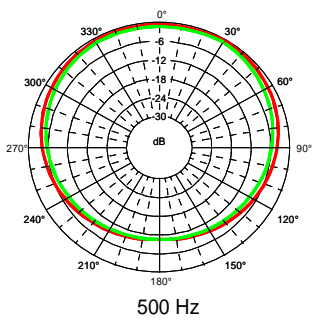
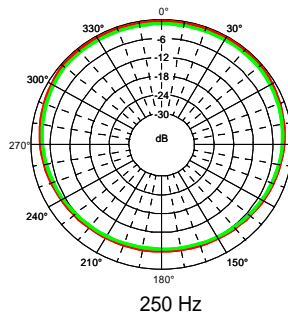
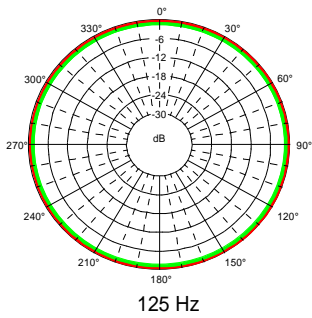

— Horizontal
— Vertical

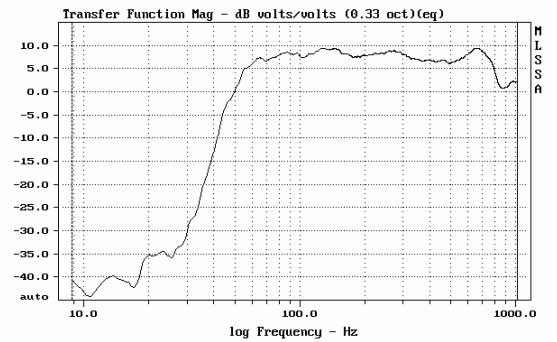

SB2, 125 frequency response

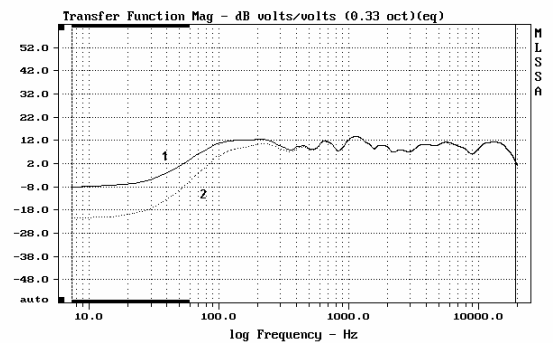

SB2, fréquence response: 1) low cut filter off 2) low cut filter on

