

INSTALL Series

2way passive loudspeaker system

Audio Performance KM15

The KM15 is a compact two-way passive system that employs a new single AP-15" ND low frequency driver mounted in a B-6 type vented enclosure. The high frequency unit is a one inch ferro fluid cooled driver coupled to a 40° / 90°x 60° AP asymmetrical horn. The system incorporates a low loss passive filter designed for flat frequency response and optimal phase alignment.

The cabinet is constructed of high quality 12mm plywood and finished with black epoxy paint.

The KM15 comes with a 35mm tube adapter.

Its multi-angle design allows you to use the KM15 in a variety of applications. By rotating the asymmetrical horn, the MP15 can be configured as front of house or as stage monitor system.

To rotate the horn, simply removed the front grill by removing it's 4x M5 screws, then remove the 4x horn's M5 screws, and put it in one of the four positions. Note that the horn carries a sticker showing the FOH and stage monitor position.

The KM15 and SUB's work together with the AP44M10 or AP48M10 amplifier or the ALC48 digital controller or as a system. The single rack-unit, height channels digital controller provides all the basic functions to get the maximum performance from the system.



DESIGNED FOR

Front of house
or
Stage monitor
system

KTV
Concert halls
Clubs
Discotheques
Theatres

Special Features

Asymmetrical horn

High efficiency

Low distortion

Processor controlled

MULTI-PURPOSE Series

KM15 Specifications

Acoustical

Frequency response (1)	50-20'000 Hz ± 3dB
Max. peak SPL (2)	138dB
Coverage	40°/90° by 60° (4 positions)
Crossover frequency (3)	1100Hz
Power handling	900W (AES) (4)

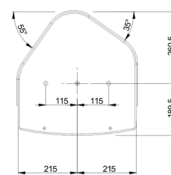
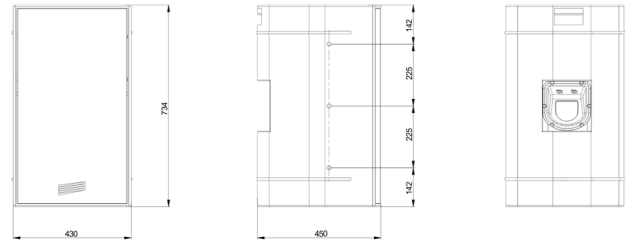

Transducers and electrical

Low frequency	15 inch, long excursion, low distortion ND cone driver
High frequency	2 inch diaphragm ND compression driver, loaded with asymmetrical horn
Nominal impedance	8 ohms
Connectors	2 x Neutrik Speakon, model NL4MP (wired in parallel) 1+: SP+, 1-: SP-, 2+, 2-: link

The coverage pattern of the asymmetrical horn.
Vertically 60° and horizontally smoothly changing from 90° to 40°

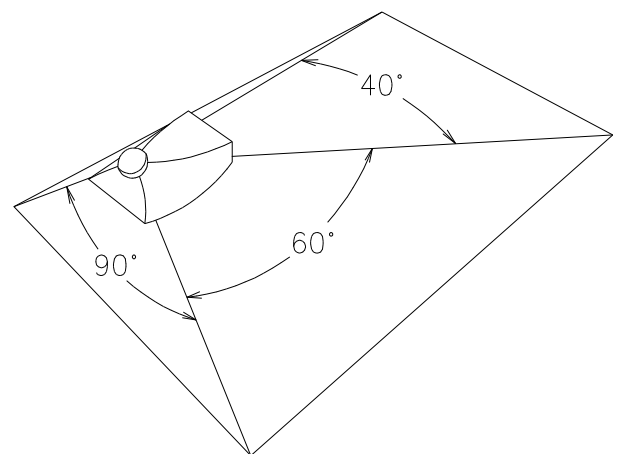

Mechanical

Cabinet shape	multipurpose FOH or floor monitor
Cabinet size (W x H x D)	734 x 430 x 450mm
Cabinet, finish	12mm plywood, black textured
Mounting system	one 35mm K&M tube stand adapter
Rigging	11x M8 screws
Protective grill	Hexagonal perforated 1.6mm steel grill covered with charcoal grey foam.
Weight	29 kg

Low Profile Stage Monitor

